

EDI FlexAir[®] Disc

Fine Pore Flexible Membrane Technology

FlexAir[®] Disc diffuser incorporates EDI advanced membrane technologies for superior aeration performance, flexibility, and reliability

- Precision die cut openings for high oxygen transfer, uniform air release, and low operating pressure
- High capacity membrane option available for maximum airflow and low operating pressure
- Advanced technology premium quality membrane materials available in EPDM or special polymer blends
- Triple check valve design prevents entry of liquid/solids into piping. Ideal for on / off applications
- Resistant to fouling and plugging for low maintenance
- Economical capital cost and ease of installation
- Rugged heavy duty construction
- Glass fiber reinforced polypropylene construction for maximum chemical, temperature, and UV resistance
- Mounts on any pipe material (PVC, ABS, CPVC, SS, etc.) or size
- Standard units IN STOCK for immediate shipment

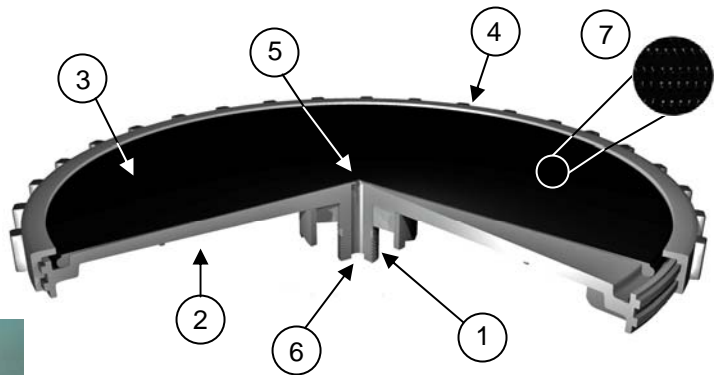

1. Threaded Connector $\frac{3}{4}$ " NPT (Male) Inlet
2. Diffuser Body
3. Flexible Membrane Media
4. Membrane Retainer Ring
5. Primary Check Valve Feature
6. Air Inlet Orifice
7. Die Cut Perforations



PRODUCT SPECIFICATION SHEET

EDI FlexAir® Disc diffusers are fine pore, flexible membrane diffusers that provide operational flexibility with maximum oxygen transfer efficiency.

FlexAir disc diffusers components are constructed of glass filled polypropylene and are suitable for a wide range of wastewater applications as well as deep tank (high temperature) applications.

FlexAir disc diffusers are configured with premium quality membrane that are engineered by the Membrane Technology division at EDI.

Alternate membrane materials are available for non-standard industrial or municipal applications. Multiple perforations are also available for optimized oxygen transfer efficiency or air handling performance.

FlexAir disc diffuser units may be operated over a wide airflow range and require minimum maintenance for long-term performance. Diffuser units may be operated intermittently as each individual diffuser features a triple check valve assembly to prevent intrusion of liquid or solids into the diffuser or air piping.

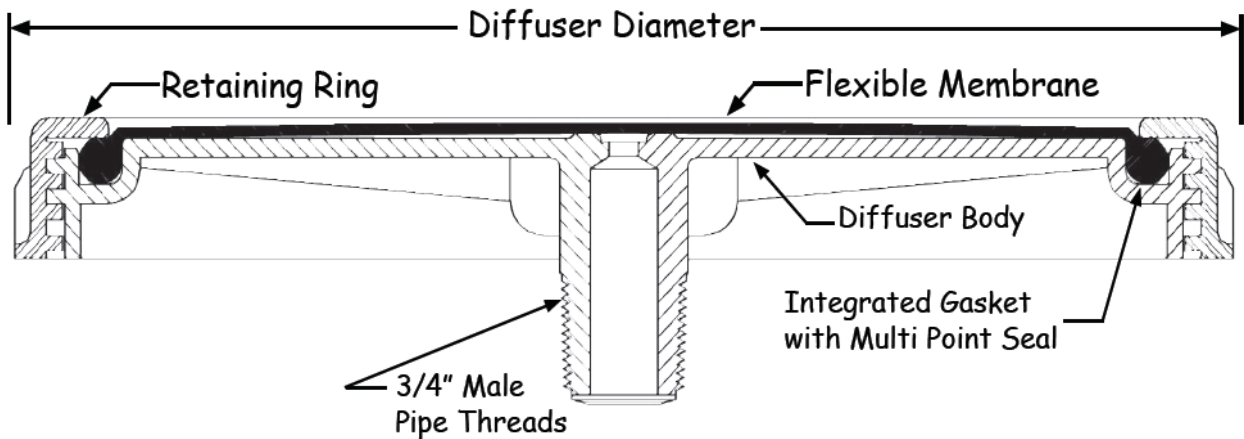

Diffuser Type	Operating Airflow		Diffuser Diameter		Active Surface Area		Dry Wt	
	scfm	m ³ _N /h	in	mm	ft ²	m ²	lbs	kgs
7" Micro	0-3	0-4.7	9	230	0.26	0.024	1.2	0.5
7" High Cap	0-7.5	0-11.9	9	230	0.26	0.024	1.2	0.5
9" Micro	0-6	0-9.5	10.9	280	0.41	0.038	1.5	0.7
9" High Cap	0-10	0-15.8	10.9	280	0.41	0.038	1.5	0.7
12" Micro	0-10	0-15.8	13.8	350	0.73	0.068	2.5	1.1
12" High Cap	0-18	0-28.5	13.8	350	0.73	0.068	2.5	1.1

- Optimum oxygen transfer efficiency is achieved when operating in the middle to low end of the airflow range. The approximate operating pressure of the diffuser at the mid-range is 13 to 16 inches.
- Operating the unit at the high end of the range will result in reduced performance and increased operating pressure. Use the maximum airflow value for short term operations such as peak loads or system maintenance.