

PRODUCT SPECIFICATION SHEET

EDI FLEXAIR[®] MiniPanel[™] Diffuser

Fine Pore Flexible Membrane Technology

High Oxygen Transfer Efficiency for Maximum Customer Value

- Highest horizontal projected diffuser area for maximum OTE performance
- Efficient geometry supports high density installations of over 65% floor coverage
- Precision die cut openings for high oxygen transfer, uniform air release, and low operating pressure
- Nano Pore[™], Micro Pore[™] and Standard perforation options available for engineered OTE and operating pressure requirements
- Advanced technology premium quality membranes available in EPDM, urethane, or special polymer blends, plus BioShield[™] and BioCide[™] technologies for reduced fouling and maintenance
- Nominal 4.75-inch (117 mm) diameter x 54-inch (1359 mm) length for a total active membrane area equal to 366 in² (0.236 m²)
- Integral triple check valve design prevents entry of liquid/solids into piping. Ideal for on / off applications
- Resistant to fouling and plugging for low maintenance
- ABS and PVC construction for maximum chemical, temperature, and UV resistance
- Spectrum[™] Saddle Mount provides maximum mechanical integrity, ease of installation and maintenance, and ability to relocate or add diffusers for process modifications
- Non-buoyant design for reduced stress on mounting connection
- Spectrum Saddle Mount mounts on any pipe material (PVC, ABS, CPVC, SS, etc.)
- Available in 4, 6, 8-inch and 110 and 160-mm pipe sizes

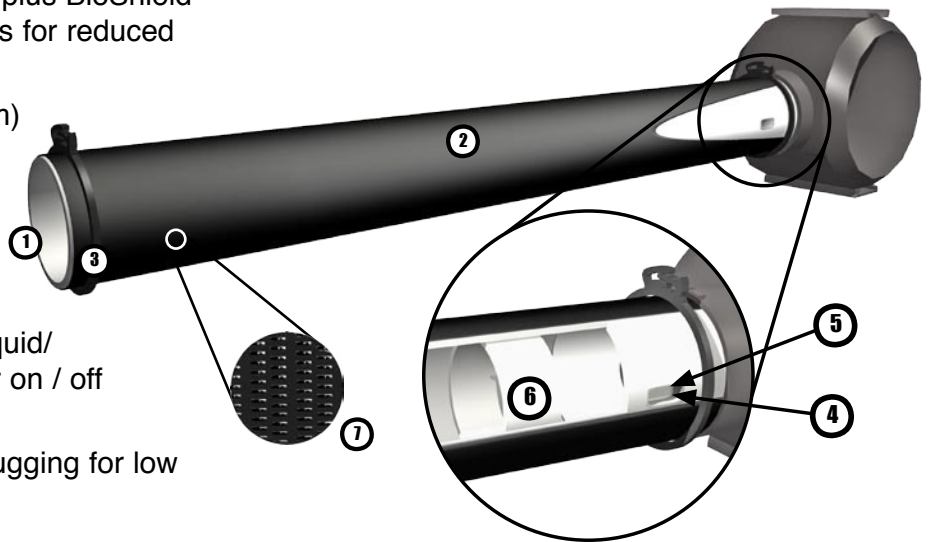

1. Membrane Support Tube
2. Flexible Membrane Media featuring Top-Half Only Perforation
3. Reuseable, Non-Metallic Membrane Retainer Clamps Standard (*Stainless Steel Clamp Optional*)
4. Check Valve Feature with non-Perforated Membrane Area
5. Air Distribution Orifices
6. Internal End Plug
7. Die Cut Perforations



www.wastewater.com
Environmental Dynamics Incorporated

30
YEARS
1975-2005

PRODUCT SPECIFICATION SHEET

EDI FLEXAIR® MiniPanel™ diffuser is a unique fine pore, flexible membrane diffuser that provides superior operational flexibility and oxygen transfer efficiency compared to other membrane or rigid fine pore (ceramic) diffusers.

The MiniPanel diffuser features an exclusive top-half only perforation design. This design produces optimum oxygen transfer efficiency performance. A full 366 in² (0.236 m²) of perforated area is provided with a single MiniPanel diffuser (732 in² [0.472 m²] per diffuser assembly). The geometry of the diffuser support high diffuser density applications over 65% floor coverage when the highest oxygen transfer efficiency is desired.

Unique to the FLEXAIR product is the ability to configure the diffuser for the objectives of the application. The MiniPanel diffuser may be configured with a standard, micro pore, or nano pore membrane for optimized OTE and operating pressure performance. All FLEXAIR diffusers are configured with premium quality membranes that are engineered by the Membrane Technologies division at EDI. Alternate membrane materials and perforation patterns are available for non-standard industrial or municipal applications.

An integral triple check valve feature prevents the backflow of liquid into the diffuser and piping. The FLEXAIR MiniPanel diffuser is ideally suited for on/off applications and requires minimal maintenance for long-term performance.

The FLEXAIR MiniPanel diffuser is constructed of PVC or ABS for maximum chemical resistance and mechanical durability. ABS construction is recommended for high temperature applications or where cold temperature durability is required.

The FLEXAIR MiniPanel diffuser is exclusively available with the Spectrum Saddle Mount for maximum mechanical durability and ease of installation and maintenance. Unique to the Spectrum Saddle Mount is the ability to relocate or add diffusers to match process demands. This feature allows the aeration system to be reconfigured to match the specific oxygen demand or air handling requirements of the process. This is particularly beneficial in BNR applications where tight dissolved oxygen control is paramount. System expansions are also easily accommodated with this feature.

For additional information on the FLEXAIR MiniPanel diffuser or other EDI products, contact EDI, visit our website at www.wastewater.com or contact a local EDI representative.

This equipment and systems are covered by US and International Patents 5587114, 6543753, 5846412, 4960546, 6497402, 5788847, 7044453, 5133876, 6770200, 7041219, 5032325, 2028914, 02820115.9, 02773737.8, 05103593.0 and Patents Pending.

Trademarks belong to Environmental Dynamics Inc and their respective trademark owners and may not be used without written permission.

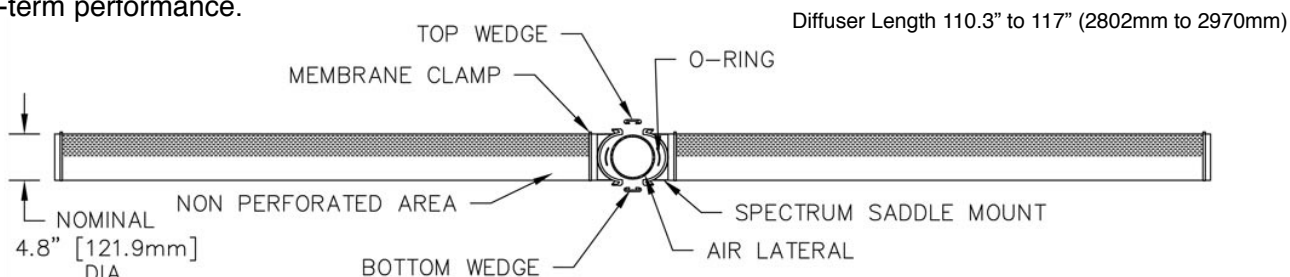

Duplex Dry Weight = 32 lbs
Duplex Operational Weight = 2.8 lbs

Diffuser Length 110.3" to 117" (2802mm to 2970mm)

A. Active Perforated Area= 732 in² (0.472m²)
B. Length Controlled by Pipe Size

Model*	Typical Airflow Continuous**	Typical Airflow Membrane DWP**
Standard	0-20 scfm (0-32 Nm ³ /hr)	6.7-17.8 in H ₂ O (1.7-4.4 kPa)
Micropore	0-10 scfm (0-16 Nm ³ /hr)	7.8-19.2 in H ₂ O (1.9-4.8 kPa)
Nanopore	0-5 scfm (0-8 Nm ³ /hr)	20.4-27.5 in H ₂ O (5.1-6.8 kPa)

* For Standard Oxygen Transfer Data, Please refer to the SOTE Spec Sheet

** Typical values shown; Special membranes & unit designs available



Environmental Dynamics Inc.
5601 Paris Road Columbia, MO 65202
USA 573-474-9456

For Parts Information:
parts@wastewater.com
www.diffuserexpress.com

For System Information:
systems@wastewater.com
www.wastewater.com